

A

B

C

D

E

F

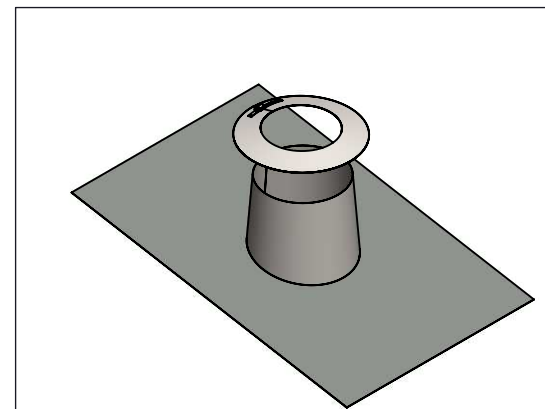
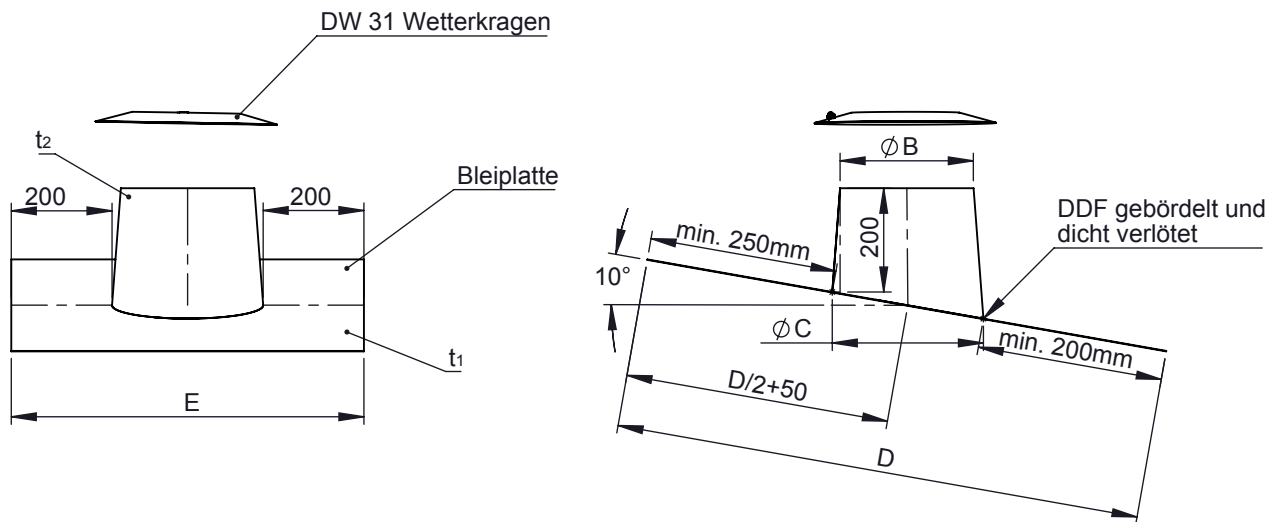

1:20

Ø	080	100	115	120	130	140	150	160	180	200	225	250	300	350	400	450	500	550	600
B	195	215	230	235	245	255	265	275	295	315	340	365	415	465	515	565	615	665	715
C	230	250	265	270	280	290	300	310	330	350	375	400	450	500	550	600	650	700	750
D	1000														1010	1060	1110	1170	1220
E	630	650	665	670	680	690	700	710	730	750	775	800	850	900	950	1000	1050	1100	1150
t ₁	1,0																		
t ₂	0,5															0,6			
kg	7,71	7,93	8,11	8,16	8,26	8,38	8,47	8,58	8,77	8,98	9,22	9,44	9,87	11,4	11,5	12,2	12,9	14,4	14,8

material: inside/outside	304/Pb		surface: inside/outside	3D		revisions-no.		A3												Scale	1:15	
																				description	DW 53 Dachdurchführung Edelstahl 5°-15° + Bleirand inkl. Wetterkragen	
										code	DW 53										Sheet	1
										drawing-no.												
revision		date		name		All rights reserved!																