

Anz. Beschreibung

1 COMFORT 15-14 BXU PM DACH



Hinweis! Abbildung kann vom Produkt abweichen.

Produktnr.: [99831285](#)

The high-efficiency Grundfos COMFORT BU PM and BXU PM pumps are designed for recirculation of domestic hot water in single- and two-family houses securing hot water instantly to all faucets. The pumps have a corrosion-resistant pump housing suitable for drinking water and are powered by a single-phase, high-efficiency ECM with permanent-magnet rotor.

The integrated digital timer has been developed for domestic hot-water recirculation in systems with either hot-water tanks or plate heat exchangers for hot-water production. The timer allows you to customise the pump's operating periods, ensuring optimal comfort while lowering energy costs. Additionally, the pump can be set to continuous operation 100 %.

COMFORT BXU PM has a built-in isolating valve and a non-return valve (fitting). This ensures that maintenance can be carried out without draining the system. The non-return valve also prevents reversed flow during operation.

Features and benefits:

- Continuous operation can be set for commissioning of the pump or 24 hours instant hot shower and tap water.
- Quick and simple electrical installation.
- Dry-running protection protects the pump against dry running during startup and normal operation.
- Easy-to-clean and lime-resistant spheric rotor.
- Noiseless operation due to liquid-lubricated bearing.
- No leakage risk due to a static seal.
- Easy maintenance and cleaning through the easy-to-separate pump head.
- No additional motor protection necessary due to integrated motor electronics.

Beschreibung	Daten
Allgemeine Informationen:	
Produktbezeichnung:	COMFORT 15-14 BXU PM DACH
Produktnummer:	99831285
EAN-Nummer:	5713834895562
Preis:	€ 413.72
Technische Daten:	
Drehzahlstufe (Nr.):	1
Maximale Förderhöhe:	14 dm
Temperaturklasse:	95
Prüfkennzeichen auf dem Typenschild:	CE, WEEE
Rückschlagklappe:	Pumpe mit eingebautem Absperr-/Rückschlagventil
Werkstoffe:	
Pumpengehäuse:	Messing
Laufrad:	Verbundwerkstoff
Installation:	
Max. Betriebsdruck:	10 bar
Anschlusstyp:	G
Nennweite:	1
Einbaulänge:	140 mm
Fördermedium:	
Fördermedium:	Wasser
Medientemperaturbereich:	2 .. 95 °C
Medientemperatur während des Betriebs:	60 °C
Dichte:	983.2 kg/m ³
Elektrische Daten:	
Leistungsaufnahme P1 bei Drehzahlstufe 3:	7 W
Netzfrequenz:	50 Hz
Bemessungsspannung:	1 x 230 V
Stromaufnahme Drehzahlstufe 3:	0.07 A
Schutzart (gemäß IEC 34-5):	IP44
Wärmeklasse (IEC 85):	F
Motorschutz:	elektronisch
Temperaturschutz:	Impedanzgeschützt
Sonstiges:	
Nettogewicht:	1.14 kg
Bruttogewicht:	1.24 kg
Länderschlüssel:	D-A-CH
Herkunftsland:	DE
Zolltarif Nr.:	84137030

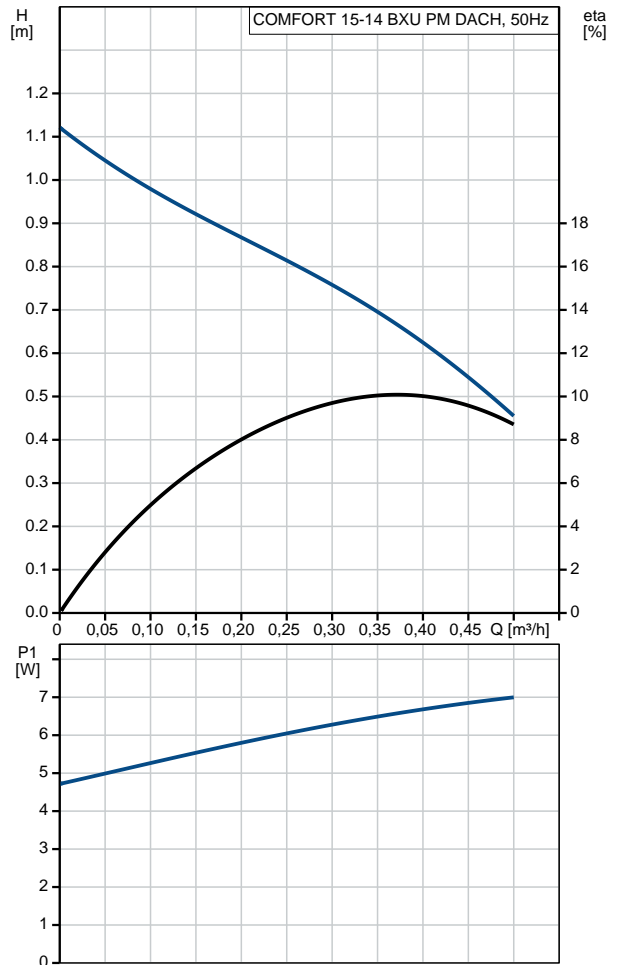

99831285 COMFORT 15-14 BXU PM DACH 50 Hz

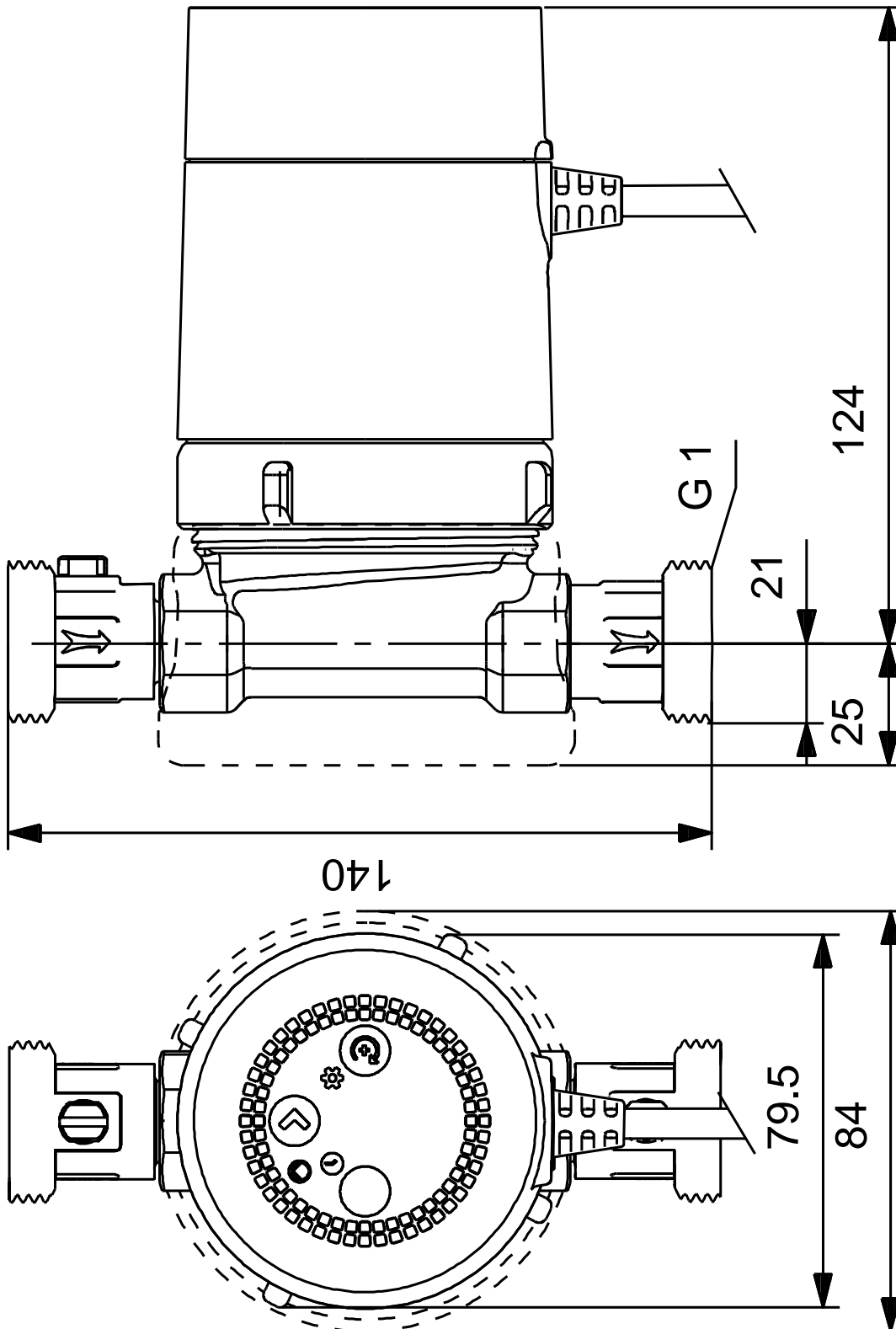

Achtung! Soweit nicht anders angegeben, handelt es sich um Millimeterangaben (mm). Die vereinfachte Maßzeichnung zeigt nicht alle Einzelheiten.

99831285 COMFORT 15-14 BXU PM DACH 50 Hz



Hinweis: Alle Einheiten in [mm] soweit nicht anders bezeichnet.